

550 / 7-26-83 JS (2)

Dr. 1635-7

DOE/AL/10563-T17  
(DE83011297)

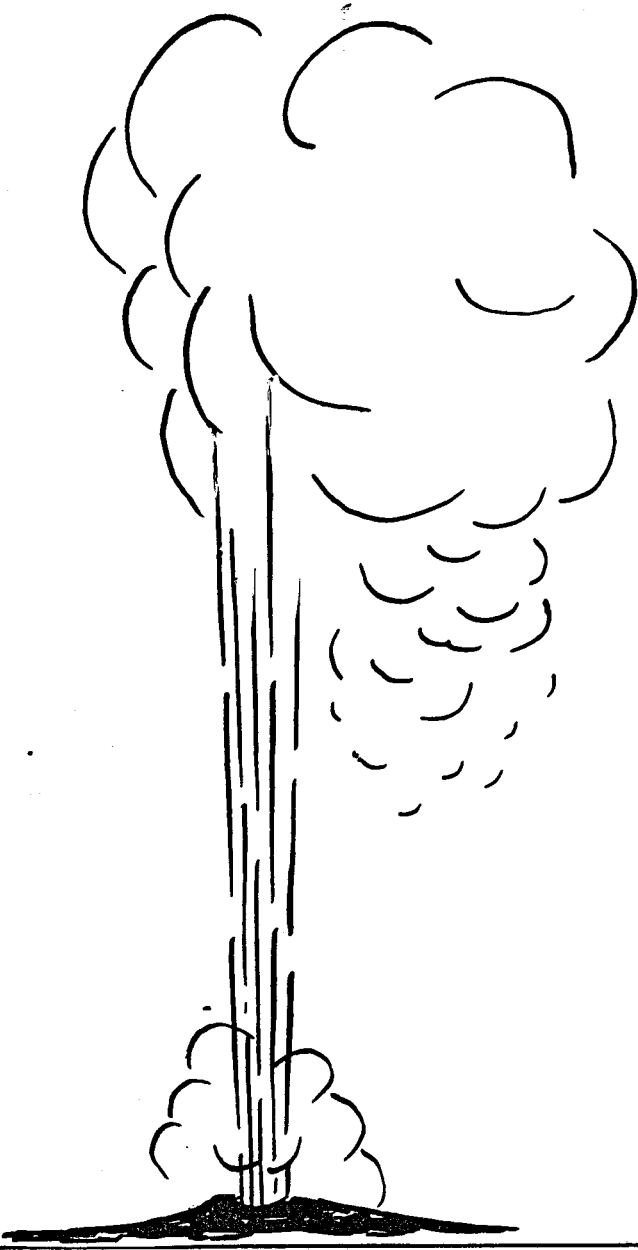

**A LABORATORY STUDY OF ACID STIMULATION  
OF DRILLING MUD DAMAGED GEOTHERMAL  
RESERVOIR MATERIALS**

**Final Report**

**May 1983**

**Work Performed Under Contract No. AC04-79AL10563**

**University Research Park  
Terra Tek Research  
Salt Lake City, Utah**

**and**

**Republic Geothermal, Inc.  
Santa Fe Springs, California**

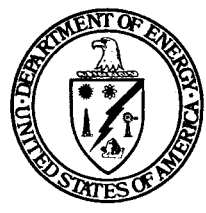

**U. S. DEPARTMENT OF ENERGY**  
**Geothermal Energy**

## **DISCLAIMER**

**This report was prepared as an account of work sponsored by an agency of the United States Government. Neither the United States Government nor any agency Thereof, nor any of their employees, makes any warranty, express or implied, or assumes any legal liability or responsibility for the accuracy, completeness, or usefulness of any information, apparatus, product, or process disclosed, or represents that its use would not infringe privately owned rights. Reference herein to any specific commercial product, process, or service by trade name, trademark, manufacturer, or otherwise does not necessarily constitute or imply its endorsement, recommendation, or favoring by the United States Government or any agency thereof. The views and opinions of authors expressed herein do not necessarily state or reflect those of the United States Government or any agency thereof.**

## **DISCLAIMER**

**Portions of this document may be illegible in electronic image products. Images are produced from the best available original document.**

## DISCLAIMER

This report was prepared as an account of work sponsored by an agency of the United States Government. Neither the United States Government nor any agency thereof, nor any of their employees, makes any warranty, express or implied, or assumes any legal liability or responsibility for the accuracy, completeness, or usefulness of any information, apparatus, product, or process disclosed, or represents that its use would not infringe privately owned rights. Reference herein to any specific commercial product, process, or service by trade name, trademark, manufacturer, or otherwise does not necessarily constitute or imply its endorsement, recommendation, or favoring by the United States Government or any agency thereof. The views and opinions of authors expressed herein do not necessarily state or reflect those of the United States Government or any agency thereof.

This report has been reproduced directly from the best available copy.

Available from the National Technical Information Service, U. S. Department of Commerce, Springfield, Virginia 22161.

Price: Printed Copy A03  
Microfiche A01

Codes are used for pricing all publications. The code is determined by the number of pages in the publication. Information pertaining to the pricing codes can be found in the current issues of the following publications, which are generally available in most libraries: *Energy Research Abstracts (ERA)*; *Government Reports Announcements and Index (GRA and I)*; *Scientific and Technical Abstract Reports (STAR)*; and publication NTIS-PR-360 available from NTIS at the above address.

Final Report

A LABORATORY STUDY OF ACID STIMULATION  
OF DRILLING MUD DAMAGED  
GEOHERMAL RESERVOIR MATERIALS

Prepared for

U.S. DEPARTMENT OF ENERGY

CONTRACT NO. DE-AC04-79AL10563

By

TERRA TEK RESEARCH  
UNIVERSITY RESEARCH PARK  
420 WAKARA WAY  
SALT LAKE CITY, UTAH 84109

MAY 1983

REPUBLIC GEOHERMAL, INC.  
11823 EAST SLAUSON AVENUE  
SANTA FE SPRINGS, CALIFORNIA 90670

# TABLE OF CONTENTS

	<u>Page</u>
LIST OF FIGURES . . . . .	ii
LIST OF TABLES. . . . .	iii
INTRODUCTION. . . . .	1
PERMEABILITY/ACIDIZATION APPARATUS DESCRIPTION. . . . .	3
EXPERIMENTAL PROCEDURE: PERMEABILITY/ACIDIZATION TESTS . . . . .	7
Sample Preparation . . . . .	7
Test Procedure . . . . .	8
TEST RESULTS AND SAMPLE DESCRIPTIONS. . . . .	12
Sample Descriptions. . . . .	12
Test #1 . . . . .	19
Test #2 . . . . .	19
Test #3 . . . . .	20
Test #4 . . . . .	20
DISCUSSION OF PERMEABILITY/ACIDIZATION TESTS. . . . .	21
PERMEABILITY/ACIDIZATION CONCLUSIONS. . . . .	23
HYDROTHERMAL ALTERATION RESULTS . . . . .	24
Mud Incubation Tests . . . . .	24
Acid Digestion Results . . . . .	26
Acid Digestion of Cuttings. . . . .	26
Acid Digestion of Drilling Muds . . . . .	28
APPENDIX I - Bulk Mineralogy Based on X-Ray Diffraction Analysis of Palygorskite Drilling Mud . . . . .	32
APPENDIX II - Bulk Mineralogy Based on X-Ray Diffraction Analysis of Sepiolite Drilling Mud. . . . .	34
APPENDIX III - Supplementary Studies of Sepiolite Drilling Muds . . . . .	36
APPENDIX IV - Preparation of Acid Solutions. . . . .	40
APPENDIX V - Composition of Attapulgitic and Sepiolite Mud Systems . . . . .	43
APPENDIX VI - Composition of Acid-Effluent-Precipitate: Results of Elemental Analysis . . . . .	44

## LIST OF FIGURES

<u>Figure</u>	<u>Title</u>	<u>Page</u>
1	Schematic of Permeability/Acidizing Apparatus . . . . .	4
2	Cup Assembly Used in Permeability/Acidization Tests . . . . .	5
3	East Mesa KGRA 20/60 Mesh Untested Sample Material. . . . .	14
4	Roosevelt KGRA 20/60 Mesh Untested Sample Material. . . . .	15
5	Post-Test East Mesa Sample, Test #1 . . . . .	16
6	Post-Test Roosevelt Sample, Test #2 . . . . .	17
7	Post-Test Roosevelt Sample, Test #4 . . . . .	18

LIST OF TABLES

<u>Table</u>	<u>Title</u>	<u>Page</u>
1	Summary of Test and Sample Conditions for Permeability/ Acidization of Two Mud Damaged Geothermal Materials . . . . .	11
2	Summary of Results for Acid Stimulation Tests . . . . .	13
3	Degree of Hydrothermal Alteration of Sepiolite Drilling Mud . . . . .	25
4	Degree of Hydrothermal Alteration of Palygorskite (Attapulgate) Drilling Mud. . . . .	25
5	Solubility of Cuttings in a 5% Hydrofluoric Acid - 10% Hydrochloric Acid Mixture . . . . .	27
5a	Solubility of Cuttings in 19% HCl Solution. . . . .	27
6	Acid Solubility of Incubated Palygorskite and Sepiolite Drilling Muds at 150°C and 100 atms Nitrogen. . . . .	29
7	X-Ray Diffraction Analysis of Palygorskite Acid Digestion Insoluble Residues. . . . .	30

## INTRODUCTION

Presented here are the results of laboratory testing performed to provide site specific information in support of geothermal reservoir acidizing programs. The testing program included laboratory tests performed to determine the effectiveness of acid treatments in restoring permeability of geologic materials infiltrated with hydrothermally altered sepiolite drilling mud. Additionally, autoclave tests were performed to determine the degree of hydrothermal alteration and effects of acid digestion on drilling muds and drill cuttings from two KGRA's. Work was performed by Terra Tek under subcontract to Republic Geothermal, Inc. (RGI) in support of DOE funded geothermal stimulation programs.

Four (4) laboratory scale permeability/acidizing tests were conducted on specimens prepared from drill cuttings taken from two geothermal formations. Two tests were performed on material from the East Mesa KGRA Well #78-30, from a depth of approximately 5500 feet, and two tests were performed on material from the Roosevelt KGRA Well #52-21, from depths of approximately 7000 to 7500 feet. Tests were performed at simulated in situ geothermal conditions of temperature and pressure. All core material was supplied by RGI.

The permeability/acidization tests included five major steps:

1. An initial brine permeability measurement was performed on the undamaged drill cuttings specimen.
2. The test specimen was infiltrated with sepiolite drilling mud which was then hydrothermally altered at simulated in situ conditions.
3. A brine permeability measurement was performed on the mud infiltrated, hydrothermally altered, sample.
4. The sample was acidized with either 5%HF-10%HCl or 15% HCl by weight acid solutions, at simulated in situ conditions.
5. A brine permeability measurement was performed on the acidized sample.

Hydrothermal alteration of attapulgite and sepiolite drilling muds was investigated using a pressurized autoclave at three different temperatures for three different lengths of time to provide a total of nine tests on each mud type. The hydrothermally altered muds were subjected to a standard x-ray diffraction analysis scheme to characterize the alteration sequence.

Additionally, acid solubility of drill cuttings and of hydrothermally altered sepiolite and attapulgite drilling muds was investigated in a pressurized and heated autoclave. Solubility of drill cuttings was determined at elevated temperature in a 5%-10% by weight hydrofluoric-hydrochloric acid mixture and a 19% hydrochloric acid solution. Solubility of drilling muds was determined at elevated temperature in both 5%HF-10%HCl and 3%HF-12%HCl acid mixtures.

## PERMEABILITY/ACIDIZATION APPARATUS DESCRIPTION

An apparatus able to simulate static infiltration of mud, simulate acid treatment at in situ pressure and temperature, and measure brine permeability was used to perform the permeability/acidization tests, and is illustrated schematically in Figure 1. Using this apparatus, it was possible to introduce mud to the sample face, induce mud infiltration into the sample, and hydrothermally alter the resulting mud cake. The apparatus allowed the introduction of acid to the mud damaged sample and acidization of the mud damaged sample at simulated in situ conditions. All components of the apparatus exposed to acid were fabricated with Hastelloy alloys to resist corrosion. The apparatus supplied brine at controlled pressures and flow rates to allow permeability measurements on test samples. Autoclave temperature was controlled using a microprocessor. Pressure was maintained with gas driven accumulators which functioned as both constant pressure pumps and as flowmeters for the brine and mud.

The test sample (composed of drill cuttings due to the lack of available core materials) was contained in a teflon lined cup, made of Hastelloy B-2 alloy. This cup is illustrated in Figure 2. A 100 mesh screen made of "Hastelloy X" alloy prevented cuttings from flowing out of the bottom of the cup. The chamber above the drill cuttings, analogous to a wellbore, allowed the introduction of mud, brine or acid to the sample. Inlet and outlet tubes to the cup assembly were made of Hastelloy C-276 alloy. The cup assembly was fitted inside the autoclave and was sealed against intrusion of the heat transfer fluid.

Pore fluid pressures upstream and downstream of the drill cuttings and pressure in the autoclave were monitored with Bourdon tube gauges. Differential pressure across the test specimen was measured using a variable reluctance

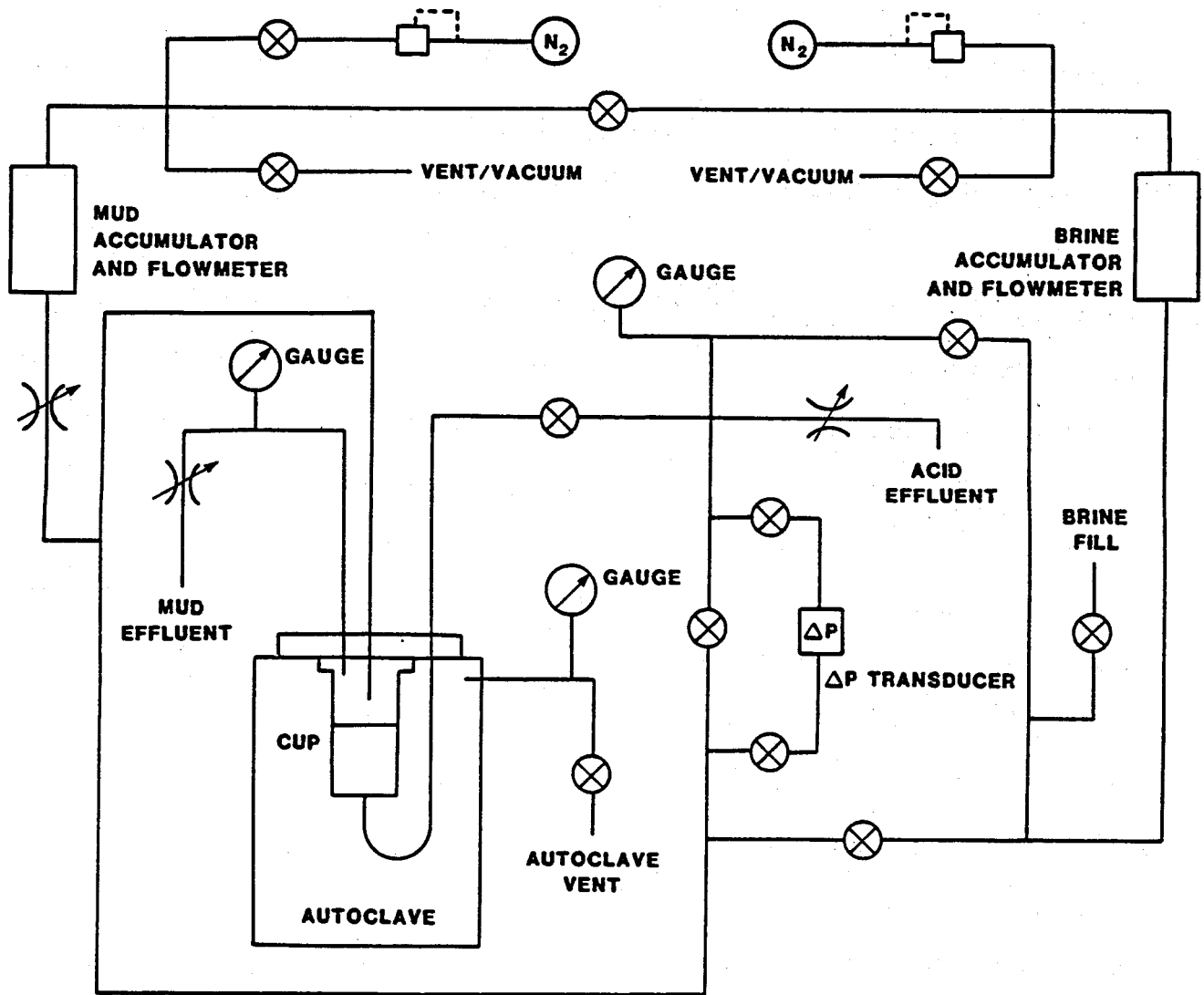

**Figure 1. SCHEMATIC OF PERMEABILITY/ACIDIZING APPARATUS**

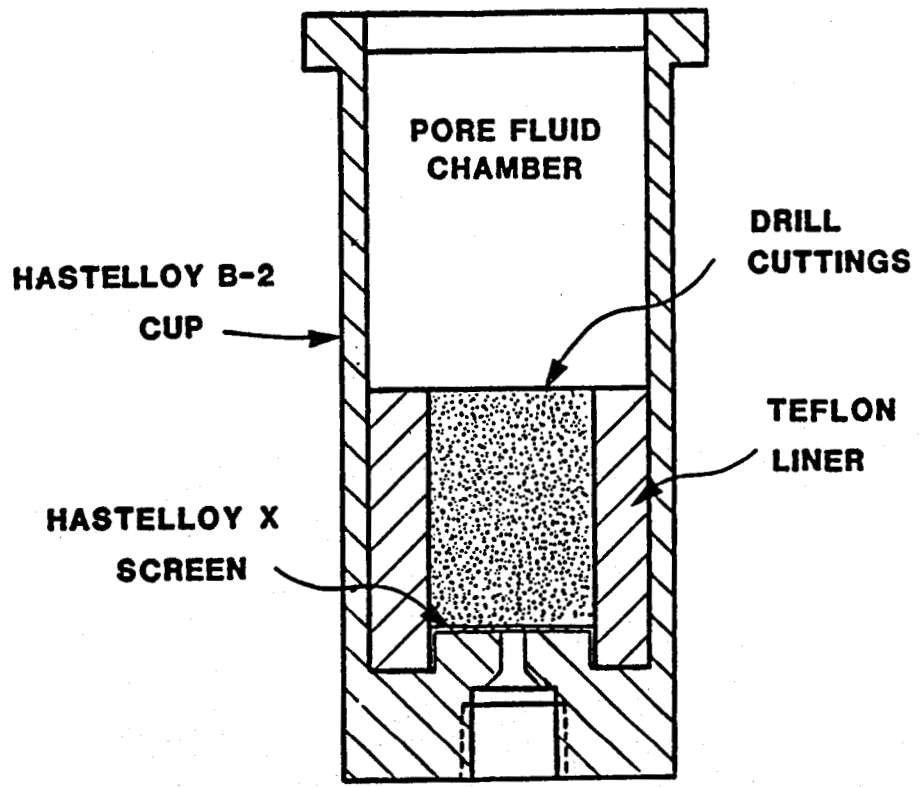

**Figure 2. CUP ASSEMBLY**

tance diaphragm type transducer. Data from the flowmeters and differential pressure transducer were recorded on an analog recorder and plotted as functions of time.

## EXPERIMENTAL PROCEDURE: PERMEABILITY/ACIDIZATION TESTS

Permeability/acidization tests included five major steps: 1) initial permeability measurement, 2) mud infiltration and hydrothermal alteration, 3) permeability measurement of the mud damaged sample, 4) acidization at simulated in situ temperature and pressure, and 5) permeability measurement of the acidized sample. Initial permeability to brine was measured at room temperature and in situ pressure. Mud was introduced into the chamber above the sample and a differential pressure was imposed to induce mud infiltration. Infiltrated mud was then hydrothermally altered at simulated in situ temperature and pressure. The permeability to brine of the mud damaged sample was measured at room temperature and in situ pressure to determine the permeability impairment due to infiltration. Acid was introduced to the sample via the chamber above the sample and was driven through the sample at in situ temperature and pressure. Permeability to brine of the acidized sample was measured at room temperature and in situ pressure to determine the amount of permeability restoration after acidization.

### Sample Preparation

Two of the test samples were composed of crushed and sieved core from the East Mesa KGRA Well #78-30, taken from a depth of approximately 5500 feet, and two were made up of drill cuttings from the Roosevelt KGRA Well #52-21, taken from a depth of approximately 7000 to 7500. Samples for all four tests were prepared from 20/60 mesh size grains sieved from source material.

Samples were prepared for testing by tamping the sieved particles into the teflon lined sample cup to obtain a specimen 3 cm in length and 2 cm in diameter. Sample mass was determined by weighing the sample cup before and after adding the drill cuttings and subtracting these values. The cup and

sample were submerged in 10,000 ppm calcium chloride brine and subjected to a vacuum of  $10^{-1}$  torr for twenty minutes to remove gas from the pore space. The vacuum was relieved, wet weight of the cup assembly was obtained, and the sample porosity determined from the weights. The cup assembly was then installed in the autoclave.

### Test Procedure

Initial brine permeability was determined at room temperature. Pore pressure was slowly increased to the specified value and flow of deaerated 10,000 ppm  $\text{CaCl}_2$  brine was initiated through the sample and continued until steady-state conditions were observed. Brine flow rate and differential pressure across the sample were measured to determine initial permeability.

Permeability was calculated from the steady-state flow test data as follows:

$$K = \frac{Q}{A} \mu \frac{l}{\Delta P}$$

where K = permeability (darcy)

Q = flow rate of permeating fluid (ml/sec)

A = cross sectional area of specimen ( $\text{cm}^2$ )

$\mu$  = viscosity of permeating fluid (cp)

l = length of specimen (cm)

$\Delta P$  = pressure drop across the specimen (atm)

All permeability data were corrected to account for apparatus related pressure drop. In the case of very large permeabilities, the pressure drop contributed by the sample was a small fraction of total measured pressure drop, which placed an upper limit of 200 darcies on permeability measurement.

After the brine permeability determination, the sample was subjected to static mud infiltration. Sepiolite mud was introduced into the chamber above

the sample and a pressure of about 50 psi was applied to the mud. A differential pressure of about 2 psi was established across the sample to induce mud cake formation and mud infiltration of the sample. During this procedure, mud filtrate flow rate was measured and used as an indicator for filter cake development. As the mud cake developed and mud infiltrated the sample, filtrate flow rate through the sample decreased. Filtrate flow rate ultimately became constant with time indicating the mud had developed a stable cake on the sample face. Differential pressure was removed from the sample when filtrate flow was observed to be constant.

To remove excess non-caked mud from the end of the specimen, brine was flushed through the chamber above the sample until the effluent was visibly free of mud particles.

Hydrothermal alteration of the mud cake was performed by increasing pore pressure and temperature to the specified in situ values and maintaining these conditions for at least 24 hours. Results of the autoclave hydrothermal alteration studies showed that a large portion of mud alteration in sepiolite occurred in the first 24 hours. At the conclusion of the alteration procedure, the sample was slowly cooled to room temperature.

The permeability of the mud damaged sample was measured using the technique outlined for the undamaged sample. The cup assembly was then removed from the autoclave, inspected to confirm mud cake development, weighed to establish the mass of the mud, and reinstalled in the autoclave.

The specimen was acidized by introducing three to four pore volumes of acid at ambient room conditions into the chamber above the specimen and then increasing temperature and pressure to in situ values. Prior to the introduction of the acid, plumbing not needed for the acidization procedure was removed from the apparatus leaving only Hastelloy alloy parts in contact with

the acid. After introduction of the acid, pore pressure was increased to the required in situ value using nitrogen as the pressurizing medium. The sample was heated to in situ temperature, allowed to equilibrate, and finally the acid was slowly forced through the sample by nitrogen while the effluent was collected. The pH of the liquid effluent was measured with narrow range indicating papers and the appearance of the effluent was noted. After all free liquid had been driven from the sample, the sample was allowed to cool, pore pressure was released, and about 20 pore volumes of brine were passed through the sample to purge remaining acid and reaction products.

Brine permeability of the acidized specimen was measured using the technique outlined previously. The cup assembly was removed from the autoclave, weighed to establish wet weight, and sample appearance was noted. Finally, the sample was removed from the cup and examined microscopically.

Presented in Table 1 is a summary of test and sample conditions. Initial sample mass and mass of the acidized sample were both obtained from wet samples.

Data for masses are accurate to  $\pm 0.01$  g. The narrow range pH indicating paper resolves pH from 7 to 0 in steps of 0.5. Temperatures and pressures were held constant to within 5%. Acid compositions were prepared as outlined in Appendix IV. Compositions of the mud systems used in this testing are given in Appendix V.

Table 1

Summary of Test and Sample Conditions  
for Permeability/Acidization of Mud  
Damaged Geothermal Materials

Test Number	1	2	3	4
Geothermal Resource Area	East Mesa	East Mesa	Roosevelt	Roosevelt
Depth	5500'	5500'	7000-7500'	7000-7500'
Sample Grain Size	20-60 mesh	20-60 mesh	20-60 mesh	20-60 mesh
Drilling Mud	Sepiolite	Sepiolite	Sepiolite	Sepiolite
Acid Composition	5%HF/10%HCl	15% HCl	5%HF/10%HCl	15% HCl
Initial Sample Mass	18.11 g	19.96 g	19.12 g	18.90 g
Mass of Absorbed Mud	4.49 g	2.46 g	3.21 g	10.45 g
Mass of Acidized Sample	17.04 g	23.34 g	20.07 g	26.15 g
Initial Porosity	57%	57%	69%	53%
Initial Pore Volume	5.4 ml	5.4 ml	6.5 ml	5.0 ml
Conditions of Hydro-thermal Alteration:				
Temperature	425°F	425°F	491°F	491°F
Pore Pressure	500 psi	500 psi	700 psi	700 psi
Duration	62 hrs	24 hrs	28 hrs	29 hrs
Acidization Conditions:				
Temperature	425°F	350°F	491°F	491°F
Pore Pressure	500 psi	500 psi	700 psi	700 psi
Duration	1 hr	1 hr	1 hr	1 hr
Acid Volume	16 ml	16 ml	20 ml	20 ml

## TEST RESULTS AND SAMPLE DESCRIPTIONS

A summary of the permeability/acidization test results is presented in Table 2 and observations and photomicrographs of the test samples are presented in following sections. Included in Table 2 is initial brine permeability, mud damaged permeability, post-acidization permeability and pH of the acidizing effluent. Descriptions of tested samples are given with the Scanning Electron Microscope photomicrographs.

In all four tests, mud infiltration and hydrothermal alteration resulted in a decrease of sample permeability. Typically the decrease in permeability was greater than one order of magnitude.

The acid effluents from all four samples had a pH of less than zero indicating the presence of free acid. This indicates that not all the acid introduced into the samples reacted during acidization processes and the free unreacted acid was washed out along with the effluent. The acid effluents were also found to contain a tan colored precipitate. An elemental analysis of one of the precipitates is presented in Appendix VI. The analysis of another precipitate sample indicated the presence of Ralstonite ( $\text{Na, Mg, Al, F}_6 \cdot \text{H}_2\text{O}$ ) in the precipitate.

Acidization of the mud damaged samples resulted in some recovery of permeability in all four tests. Recovery ranged from 3% to greater than 100% of the initial brine permeability.

### Sample Descriptions

Photomicrographs of the untested and tested samples are presented in Figures 3 to 7 along with a brief sample description. Each figure includes a 50x magnification photo in the lower portion and a 100x magnification in the

Table 2

Summary of Test Results for  
Acid Stimulation Tests

Test Description	East Mesa Material with Sepiolite Mud Acidized with		Roosevelt Material with Sepiolite Mud Acidized with	
	5%HF/10%HCl	15% HCl	5%HF/10%HCl	15% HCl
Initial Brine Permeability	>200 darcy	6.7 darcy	>200 darcy	>200 darcy
Mud Damage Brine Permeability	17 darcy	3.9 darcy	0.64 darcy	3.2 darcy
Post Acidization Brine Permeability	>200 darcy	7.5 darcy	51 darcy	6.3 darcy
pH of Effluent	≤0	≤0	≤0	≤0

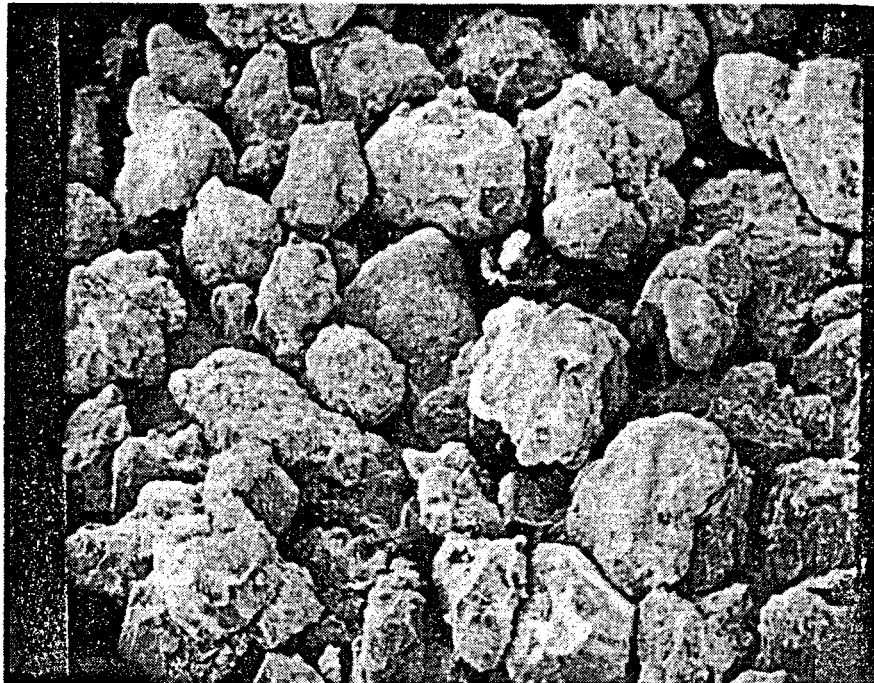

Figure 3. East Mesa KGRA 20/60 mesh untested sample material shown at 100x and 50x magnifications. East Mesa material is more uniform in size than Roosevelt material and has rounded, rough surfaces.

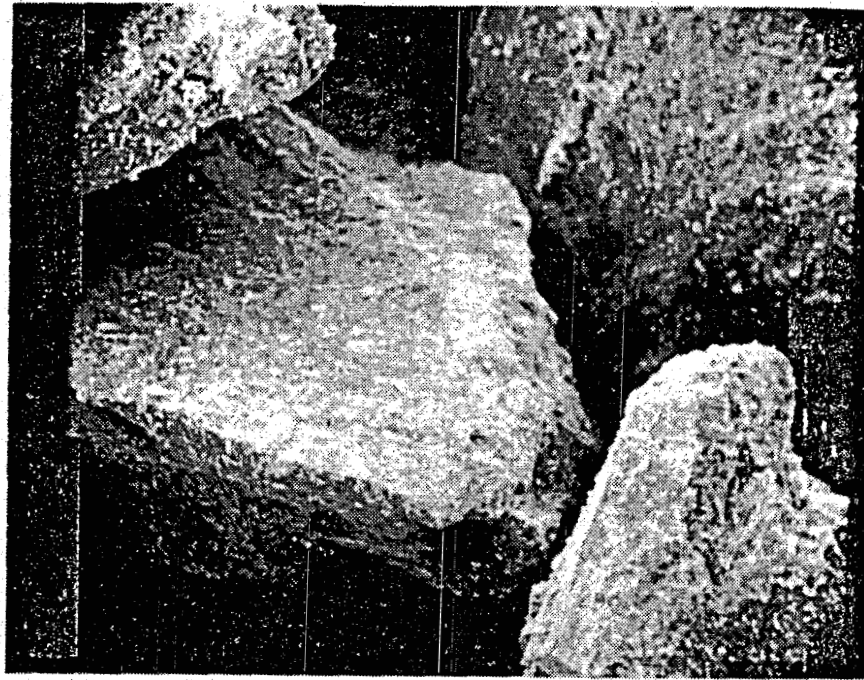

Figure 4. Roosevelt KGRA 20/60 mesh untested sample material shown at 100x and 50x magnifications. Roosevelt material has a greater proportion of larger particles with smoother and more angular particles.

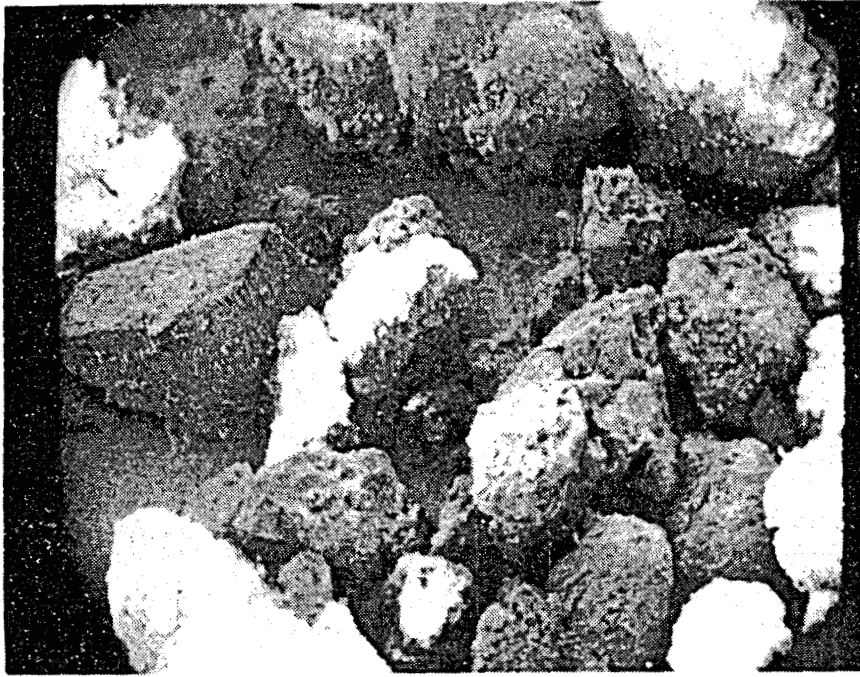

Figure 5. Post-Test East Mesa Sample, Test #1, shown at 100x and 50x magnifications. Particle surfaces are etched and mud particulate material is visible.

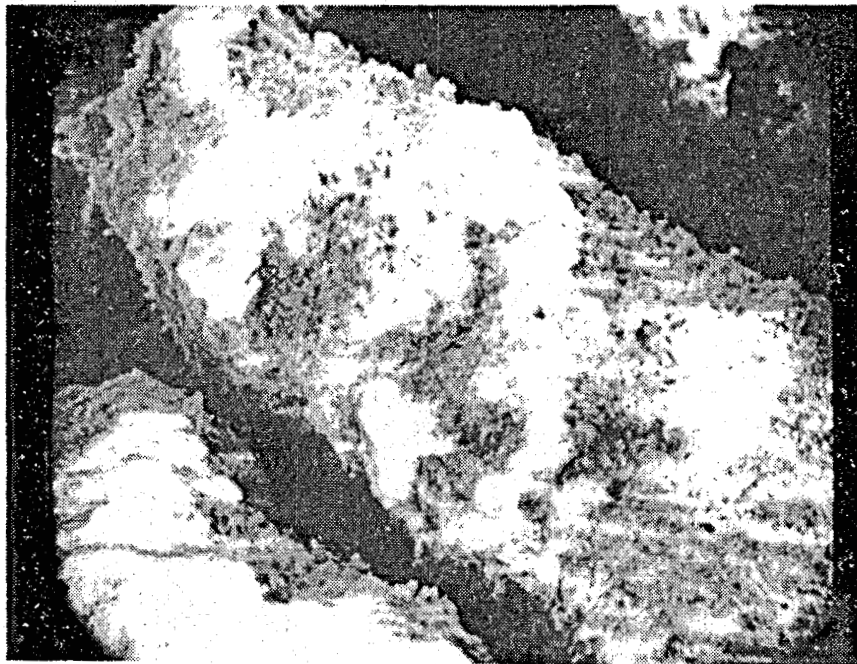

Figure 6. Post-Test Roosevelt Sample, Test #3, shown at 100x and 50x magnifications. Most surfaces are severely etched. Sharp angular particles have been rounded. Some mud particles are visible.

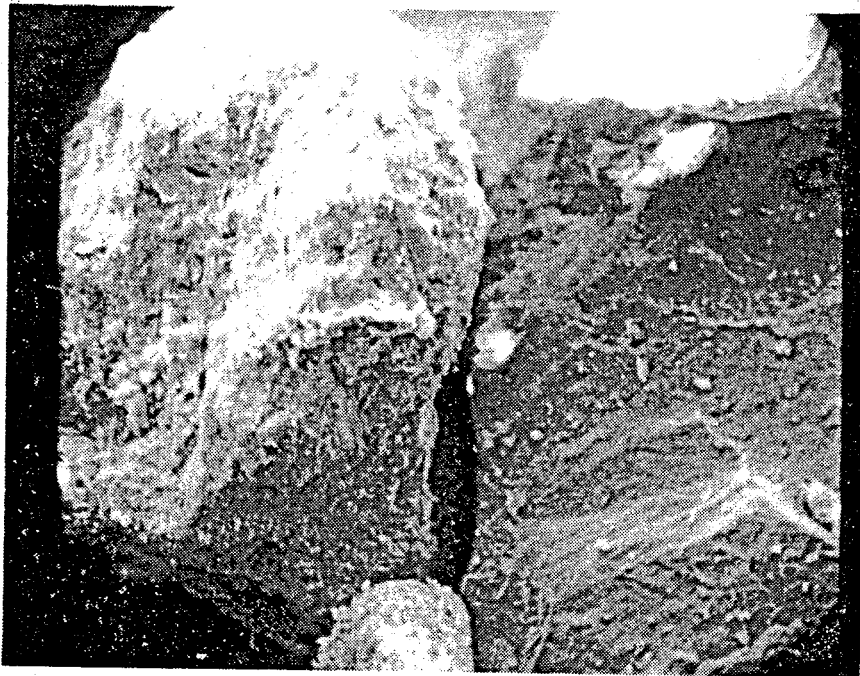

Figure 7. Post-Test Roosevelt Sample, Test #4, shown at 100x and 50x magnifications. The smooth surfaces show very little etching. Mud particles are visible.

upper portion of the page. No photos of the sample used for test #2 were produced.

As shown in Figures 3 and 4, the Roosevelt material is more angular and has a greater proportion of larger particles than the East Mesa material. East Mesa material was more uniform in size and had rougher surfaces than the Roosevelt. Obtaining uniform distribution of particle size during rock crushing to 20-60 mesh size was not always possible. Due to the cleavage preference of the Roosevelt sample material, fewer small particles were produced during crushing.

After each test, the sample was removed and inspected. Observations made during these examinations are presented below.

#### Test #1

The acidized sample was essentially free of drilling mud. However, a discrete volume of the sample (c.a. 25%) had not completely reacted with the acid, i.e., some channeling had occurred. Microscopic examination revealed very few mud particulates, many liberated silica fines, and etching of the silica grains. The sample had expanded several millimeters above Teflon insert. The Acid Digestion Results (discussed in detail under the section on Hydrothermal Alteration Results) of untested East Mesa material in a 19% HCl solution show that some gas is produced during the process. This gas production is one of the factors leading to the sample expansion. Other factors such as clay swelling may also contribute to the observed expansion.

#### Test #2

Examination of the acidized sample revealed very few mud particulates. Some evidence of channeling could be seen, but no severe etching was visible. The top of the sample was slightly coagulated with small amounts of mud fines.

Sample was found to expand ~1/2 cm above teflon insert after the acid treatment.

### Test #3

The sample showed very few mud particulates in the lower 3/4 of the sample. Some mud particles were visible near the top and in the expanded region above the teflon insert. Sample particles near the top had coagulated and formed discrete lumps which were held together with mud particles. Most particles had been etched by the acid. The sample expanded ~3 mm above the teflon insert.

### Test #4

Examination revealed the upper half of the sample was lighter in color and contained more mud particles than the lower half of the sample. Sample particles near the top had coagulated and formed discrete lumps which were held together with mud particles. The sample expanded ~1 cm above the teflon insert.

## DISCUSSION OF PERMEABILITY/ACIDIZATION TESTS

The permeability/acidization tests revealed two major phenomena. First, unconsolidated granular specimens exhibit large decreases in permeability when infiltrated by sepiolite drilling mud and subsequently subjected to hydrothermal alteration. Second, treatment of a mud damaged sample with HCl/HF acid systems significantly restored permeability. Treatment with HCl acid systems restored some permeability to the mud damaged sample, but was less effective than HCl/HF systems.

The decrease in brine permeability due to mud damage is significant. Post-acidization damage recovery is also significant, although it shows some variation from sample to sample. Roosevelt samples showed greater sensitivity to mud damage and poorer recovery as compared to the East Mesa samples. This observation perhaps correlates with the visual observation (Figures 3-7) that the Roosevelt samples contained a larger fraction of 20 mesh cuttings.

The depth to which mud infiltrated each sample varied. Mud particulates were visible in the filtrate effluent in Test #1 and in Test #4. No mud was seen in the effluent in Test #2 and #3. This was probably the result of inhomogeneities and channeling.

Acidizing increased permeability of all four mud damaged samples. Restoration of permeability is most pronounced with a HCl-HF acid mixture where permeabilities recovered by several hundred percent. This recovery is not unexpected in that hydrofluoric acid dissolves sepiolite (a magnesium silicate) as well as minerals in the sample. The post-test photomicrographs reveal a considerable degree of HF etching of grains in both the East Mesa and Roosevelt samples, but very little etching of grains when only hydrochloric acid was used. Samples treated with HCl showed recovery in permeability, but to a smaller degree than those treated with HCl-HF. This smaller recovery is not

unexpected in that HCl does not dissolve sepiolite. In all tests, the acid did react with the samples, but not all of the acid was consumed during the reaction as evidenced by the low pH of the effluent.

Some channeling of acid flow occurred in the samples. Evidence of this channeling was seen in the Hastelloy X screen used to prevent drill cuttings from leaving the cup assembly. When exposed to acid, Hastelloy X acquires a black coating. After acidization of the samples, the screen was examined and on occasion showed an irregular black coating, indicating channeling of the acid flow. Further evidence was seen in the samples after testing. Parts of the samples showed signs of acid reaction while others did not. This was evidenced by lumps of coagulated drill cuttings and unreacted mud fines found in the tested sample.

During these experiments, a certain amount of corrosive interaction occurred between the acid and the various parts of the system. Visual inspection revealed that the Hastelloy-C components downstream of the sample pitted significantly, while the upstream components, made of Hastelloy B, displayed no visible corrosion. The elemental analysis of the acid-effluent-precipitate, reported in Appendix VI, revealed the precipitate to be composed largely of chromium and molybdenum with lesser amounts of nickel, copper and zinc. This is most likely due to the acid-metal interactions. The precipitate was also found to contain sodium, potassium, magnesium, iron and aluminum. In a later analysis, these elements were found to occur as the mineral Ralstonite (Na, Mg, Al,  $F_6 \cdot H_2O$ ) in the precipitate.

## PERMEABILITY/ACIDIZATION CONCLUSIONS

- The permeability of East Mesa and Roosevelt KGRA unconsolidated drill cuttings is typically decreased by an order of magnitude when infiltrated by sepiolite drilling mud and subjected to subsequent hydrothermal alterations.
- Acidization of mud infiltrated East Mesa and Roosevelt KGRA samples helps recover some fraction of the initial permeability. Recovery is greater when hydrofluoric/hydrochloric acid mixtures are used.
- A certain amount of flow channeling occurred in the laboratory tests which limited the overall effectiveness of acid stimulation of mud damaged geologic materials.

## HYDROTHERMAL ALTERATION RESULTS

### Mud Incubation Tests

Samples of as-received attapulgite and sepiolite were incubated at temperatures of 150°C, 215°C and 250°C for periods of up to 125 hours. Compositions of these mud systems are given in Appendix V. Incubation runs were performed using a teflon-lined high temperature-high pressure autoclave. The sample charges were not stirred. Runs were carried out at a nominal pressure of 100 atmospheres nitrogen. The test results are summarized in Tables 3 and 4. The as-received mud samples and incubated mud samples were all subjected to a standard x-ray diffraction analysis scheme in order to characterize the hydrothermal alteration sequence. The analytical scheme involved x-ray analysis of air-dried and glycolated glass slide clay mounts. The air-dried sample was subjected to x-ray analysis, glycolated, and then reanalyzed. Subsequently, the glycolated sample was heated to 300°C and then 550°C for one hour periods. X-ray analyses were immediately performed after each heating episode. The results of x-ray analyses are presented for the attapulgite and sepiolite mud samples in Appendices I and II, respectively.

The mud samples were washed repeatedly to remove soluble salts which promote flocculation of clay particles. About 30 ml of each mud suspension was diluted by ~70 ml of deionized water and 1 ml of saturated sodium polyphosphate solution was then added to promote dispersion of clay particles. The mud was dropped from suspension by centrifuging and the supernatant liquid discarded. The mud was redispersed into deionized water and again spun down. The mud was washed four times in this manner. Oriented clay mounts were prepared by drying a suspension of <2 μm material onto glass slides. X-ray diffraction patterns were obtained from air dried, glycolated (60°C for 10

Table 3

## Degree of Hydrothermal Alteration of Sepiolite Drilling Mud

Sample Number	Treatment	Absolute Peak Heights		Ratio S/M
		Sepiolite (S)	Montmorillonite (M)	
RGI-11	As-received	30	0	$\infty$
RGI-12A	24 hrs @ 150°C	28	1	28
RGI-13A	48 hrs @ 150°C	26	1	26
RGI-14A	96 hrs @ 150°C	27	1	27
RGI-18A	24 hrs @ 215°C	18	3	6.00
RGI-19A	48 hrs @ 215°C	28	5	5.60
RGI-20A	72 hrs @ 215°C	20	8	2.50
RGI-15A	24 hrs @ 250°C	30	6	5.00
RGI-16A	48 hrs @ 250°C	24	12	2.00
RGI-17A	72 hrs @ 250°C	18	17	1.06

Table 4

## Degree of Hydrothermal Alteration of Palygorskite (Attapulgit) Drilling Mud

Sample Number	Treatment	Absolute Peak Heights		Ratio P/M
		Palygorskite (P)	Montmorillonite (M)	
	As-received	44	25	1.80
RGI-8A	24 hrs @ 150°C	29	30	0.97
RGI-9A	48 hrs @ 150°C	24	27	0.89
RGI-10A	96 hrs @ 150°C	20	30	0.67
RGI-5A	24 hrs @ 215°C	10	12	0.83
RGI-6A	48 hrs @ 215°C	15	35	0.43
RGI-7A	72 hrs @ 215°C	10	45	0.22
RGI-1A	24 hrs @ 250°C	15	15	1.00
RGI-3A	48 hrs @ 250°C	17	25	0.68
RGI-4A	125 hrs @ 250°C	12	25	0.48

hours or more), and heated samples (300°C and 550°C for one hour or longer at each temperature).

The major effect of heating is hydrothermal alteration of both mud types to smectite (montmorillonite). Tables 3 and 4 summarize the degree of hydrothermal alteration for both mud types in terms of the absolute peak height ratios of palygorskite/montmorillonite (P/M) and sepiolite/montmorillonite (S/M). The term palygorskite is equivalent to attapulgite. Use of the term palygorskite, however, is preferred because this term is referenced in the x-ray diffraction standard patterns.

In the case of palygorskite, the greatest degree of hydrothermal alteration occurred at 215°C. The least amount of hydrothermal alteration occurred at 150°C. In the case of sepiolite, the degree of hydrothermal alteration continuously increased with increasing temperature.

Supplementary studies were performed on sepiolite drilling mud to assess the amount of montmorillonite in the as-received mud as well as the effect of kaolinite on sepiolite. The results of this work are presented in Appendix III.

### Acid Digestion Results

The acid solubility of rock cuttings and incubated sepiolite and palygorskite drilling muds were evaluated. For the cutting samples, a 5%-10% hydrochloric acid-hydrofluoric acid solution and a 19% HCl solution were used. Solubility of drilling mud samples was determined in both 5% hydrofluoric acid-10% hydrochloric acid and 3% hydrofluoric acid-12% hydrochloric acid solutions. Acid solutions were prepared as outlined in Appendix IV.

#### Acid Digestion of Cuttings

Acid solubility of rock cuttings from the Roosevelt Hot Springs area and from East Mesa was determined in 5% HF-10% HCl acid at room temperature and at

Table 5

Solubility of Cuttings in a 5% Hydrofluoric Acid - 10% Hydrochloric Acid Mixture

Material	Terra Tek Sample Number	Sample Weight (gm)	Acid Weight (gm)	Weight Ratio Acid/Sample	Incubation Conditions	Insoluble Residue Weight (gm)	Percent Solubility	Normality of Spent Acid
Roosevelt	2023	0.4488	57.4377	127.98	Ambient	0.0987	78.01	4.28
East Mesa	2024	0.4934	65.1537	132.0505	Ambient	0.0580	88.25	4.40
Roosevelt	2021	0.4999	58.0198	116.06	150°C; 100 atms	0.0411	91.78	4.02
East Mesa	2022	0.4746	50.3797	106.15	150°C; 100 atms	0.0066	98.61	4.28

27

Table 5a

Solubility of Cuttings in 19% HCl Solution

Material	Sample Weight (gm)	Acid Weight (gm)	Weight Ratio Acid/Sample	Incubation Conditions	Percent Solubility
East Mesa	4.97	54.65	11.00	Ambient	5.8
Roosevelt	5.81	54.65	9.41	Ambient	7.5

150°C and 100 atms nitrogen. Results are summarized in Table 5. The normality of the original acid mixture was 4.17. In several runs, spent acid normality increased slightly suggesting that a small amount of solution was evaporated during the incubation period. However, the acid to sample ratio was of such a magnitude as to suggest that actual acid consumption was negligible. Spent acid also appeared to be buffered at a pH of about 6.0 probably due to dissolved silicic acid and carbonate species. All samples were incubated for 24 hours. In general, significantly more sample is digested at 150°C. East Mesa cutting material was significantly more soluble than Roosevelt cuttings at both ambient and elevated temperatures.

Acid solubility of drill cuttings from the Roosevelt and East Mesa KGRA's was determined in 19% HCl at room temperature and pressure. Results are summarized in Table 5a. A known mass of cuttings was stirred in acid for three hours at ambient room conditions. The cuttings were then filtered, dried in an oven, and weighed to determine loss in mass. CO<sub>2</sub> gas was evolved during these tests indicating the presence of carbonates.

#### Acid Digestion of Drilling Muds

Samples of hydrothermally altered sepiolite and palygorskite drilling muds were incubated in 5% HF-10% HCl and 3% HF-12% HCl solutions for 24 hour periods at 150°C and 100 atms nitrogen. Sepiolite mud sample RGI-17A had previously been incubated for 72 hours at 250°C. Palygorskite mud sample RGI-4A had previously been incubated for 125 hours at 250°C. The analytical results are summarized in Table 6. In general, palygorskite mud was significantly more soluble in a 5%HF-10%HCl acid mixture than in a 3%HF-12%HCl acid mixture. The reverse situation was observed for sepiolite. X-ray diffraction analysis of the insoluble residue from both palygorskite digestion runs were carried out. Results are summarized in Table 7. These results indicate that

Table 6

Acid Solubility of Incubated Palygorskite and Sepiolite  
Drilling Muds at 150°C and 100 atms Nitrogen\*

Mud Type	Terra Tek Sample Number	Mud Weight (gm)	Acid Composition (HF-HCl)(%)	Acid Weight (gm)	Mass Ratio Acid/Mud	Insoluble Residue (gm)	Percent Solubility	Normality of Spent Acid
Sepiolite	2025	0.3304	5-10	47.8707	144.89	-- <sup>+</sup>	50.06	6.96
Palygorskite	2026	0.5032	5-10	69.1185	137.36	0.0983	80.47	6.84
Sepiolite	2027	0.5295	3-12	66.1189	124.87	0.1157	78.15	4.67
Palygorskite	2028	0.5469	3-12	65.2809	119.37	0.2425	55.66	5.34

\*Normality of as-mixed 5%HF-10%HCl and 3%HF-12%HCl acid solutions were 4.17 N and 5.34N, respectively.  
<sup>+</sup>The solid residue was gelatinous and could not be removed from the filter paper. Thus, this estimate for insoluble residue could be significantly in error. In general, visual examination of insoluble residues suggested that sepiolite was significantly more soluble than palygorskite in both acid mixtures.

Table 7

X-Ray Diffraction Analysis of Palygorskite  
Acid Digestion Insoluble Residues

Acid Mixture (HF-HCl)(%)	Barite (BaSO <sub>4</sub> )	Celsian (BaAl <sub>2</sub> SiO <sub>8</sub> )	Edingtonite (BaAl <sub>2</sub> Si <sub>3</sub> O <sub>10</sub> ·4H <sub>2</sub> O)	Hollandite (MnBaM <sub>6</sub> O <sub>14</sub> )	Gorceixite (Ba,Ca,Sr,Al, PO·OH·2H <sub>2</sub> O)	BaFeMn <sub>7</sub> O <sub>16</sub>
5-10	Very Abundant	Common	--	Trace	Trace*	Common†
3-12	Very Abundant	--	Abundant	Trace	Trace	--

\*Possibly an alteration product of apatite.

†Brownish, very fine-grained.

the insoluble residue is mostly original barite from the drilling muds and possibly alteration products of both barite and apatite. Although sepiolite insoluble residues were not analyzed, mineralogy is most likely similar to residues obtained from palygorskite runs.

APPENDIX I

Bulk Mineralogy Based on X-Ray Diffraction  
Analysis of Palygorskite Drilling Mud

<u>Terra Tek Sample Number</u>	<u>Sample Description</u>	<u>Mineralogy</u>
RGI-2A	As- Received	Palygorskite - Very Abundant Montmorillonite - Common Sepiolite - Trace
<hr/>		
<u>150°C Incubation</u>		
RGI-8A	24 hours	Palygorskite - Abundant Montmorillonite - Abundant Sepiolite - Minor Muscovite/Illite - Minor
RGI-9A	48 hours	Montmorillonite - Abundant Palygorskite - Abundant Sepiolite - Minor Muscovite/Illite - Minor
RGI-10A	96 hours	Montmorillonite - Abundant Palygorskite - Abundant Muscovite/Illite - Minor Sepiolite - Trace
<hr/>		
<u>215°C Incubation</u>		
RGI-5A	24 hours	Montmorillonite - Abundant Palygorskite - Abundant Muscovite/Illite - Minor Sepiolite - Minor
RGI-6A	48 hours	Montmorillonite - Very Abundant Palygorskite - Abundant Sepiolite - Minor Muscovite - Minor
RGI-7A	72 hours	Montmorillonite - Very Abundant Palygorskite - Common Muscovite - Minor Calcite - Trace Sepiolite - Trace

Terra Tek  
Sample  
Number

Sample  
Description

Mineralogy

250°C Incubation

RGI-1A	24 hours	Montmorillonite - Abundant Palygorskite - Abundant Muscovite/Illite - Minor
RGI-3A	48 hours	Montmorillonite - Abundant Palygorskite - Common Muscovite/Illite - Minor Sepiolite - Trace Kaolinite - Trace
RGI-4A	125 hours	Montmorillonite - Very Abundant Palygorskite - Common Muscovite/Illite - Minor

APPENDIX II

Bulk Mineralogy Based on X-Ray Diffraction  
Analysis of Sepiolite Drilling Mud

<u>Terra Tek Sample Number</u>	<u>Sample Description</u>	<u>Mineralogy</u>
RGI-11	As- Received	Sepiolite - Abundant Muscovite - Common Dolomite - Common Kaolinite - Minor
<hr/>		
<u>150°C Incubation</u>		
RGI-12A	24 hours	Sepiolite - Abundant Muscovite - Abundant Kaolinite - Minor Dolomite - Minor to Common Montmorillonite - Minor
RGI-13A	48 hours	Sepiolite - Abundant Muscovite - Abundant Kaolinite - Minor Dolomite - Common Montmorillonite - Trace Vermiculite - Trace
RGI-14A	96 hours	Sepiolite - Abundant Muscovite - Common Dolomite - Common Montmorillonite - Minor Berthierine - Minor Kaolinite - Minor Calcite - Minor
<hr/>		
<u>215°C Incubation</u>		
RGI-18A	24 hours	Sepiolite - Common to Abundant Muscovite - Common to Abundant Dolomite - Common Montmorillonite - Trace to Minor Berthierine - Minor Kaolinite - Minor Calcite - Trace
RGI-19A	48 hours	Same as RGI-18A
RGI-20A	72 hours	Sepiolite - Common to Abundant Muscovite - Common to Abundant Dolomite - Common Montmorillonite - Minor to Common

Terra Tek  
Sample  
Number

Sample  
Description

Mineralogy

Berthierine - Minor  
Kaolinite - Minor  
Calcite - Trace to Minor

---

250°C Incubation

RGI-15A	24 hours	Sepiolite - Abundant Muscovite - Common Dolomite - Common Montmorillonite - Minor Berthierine - Minor Kaolinite - Minor Calcite - Trace
RGI-16A	48 hours	Same as RGI-15A
RGI-17A	72 hours	Sepiolite - Common Montmorillonite - Common Muscovite - Common Dolomite - Common Berthierine - Minor Kaolinite - Minor Calcite - Minor

## APPENDIX III

### SUPPLEMENTARY STUDIES OF SEPIOLITE DRILLING MUDS

The actual amount, if any, of montmorillonite in as-received sepiolite drilling mud was re-evaluated to determine if:

1. As-received sepiolite mud contained significant amounts of montmorillonite.
2. Kaolinite in as-received mud reacts with sepiolite to form montmorillonite.
3. Sepiolite undergoes significant conversion to montmorillonite as a result of hydrothermal alteration at elevated temperature.
4. A silver membrane clay sample mount yields analytical results substantially different from those obtained with a glass plate sample mount.

#### Procedure

Mud was boiled in a sodium chloride solution and subsequent x-ray analysis was carried out using silver membrane and glass plate mounts. Kaolinite abundances were carefully documented in as-received and incubated mud samples. High temperature mud samples were re-analyzed using silver membrane mounts. Results of this study were compared to previous results.

Sample RGI-11 was boiled for 12 hours in a saturated (25°C) NaCl solution which contained a small amount of detergent.

The clay fraction was extracted from all samples as follows:

Mud was diluted in ~100 ml of deionized water containing ~1 ml of saturation polyphosphate. The mud was recovered by centrifuging and the liquid decant was discarded. The mud was then re-suspended by agitation for 1 to 2 minutes in a blender with a fresh aliquote of polyphosphate-containing deionized water. After the third washing, only the +2 $\mu$ m particles were removed by centrifuging. The remaining clays in suspension were mounted on silver membranes (0.45

µm pore size) by vacuum filtration. Processed clay from sample RGI-11 was also dried onto glass slides.

Each of the samples were analyzed after air drying, glycolation (60°C for 12 hours) and heating (300°C and 550°C for one hour). Analysis was performed on a Philips XRG-2600 instrument. Copper K $\alpha$  radiation was used at 40 KV and 20 MA.

## Results

Three sepiolite mud samples, stored in plastic bottles, were re-analyzed:

<u>Terra Tek Sample No.</u>	<u>Description</u>
RGI-11	As-received sepiolite mud
RGI-18	Sepiolite mud after incubation at 250°C for 24 hours
RGI-15	Sepiolite mud after incubation at 215°C for 24 hours

Comparison of the x-ray diffraction patterns of the treated and untreated clay shows that boiling in NaCl dissolved dolomite which occurs in the untreated sample. The treated sample has a much more intense sepiolite peak relative to the 10A muscovite peak:

<u>Treatment</u>	<u>Mount</u>	<u>Measurements on Glycolated Samples</u>	<u>Ratio</u>
Boiled in NaCl	Silver Membrane	Area 12A Peak/Area 10A Peak Peak Height 12A/Peak Height 10A	166/8 = 21 33/8 = 4
	Glass Slide	Area 12A Peak/Area 10A Peak Peak Height 12A/Peak Height 10A	54/6 = 9 12/6 = 2
Not Boiled	Silver Membrane	Area 12A Peak/Area 10A Peak Peak Height 12A/Peak Height 10A	19/3 = 6 5/3 = 2
	Glass Slide	Area 12A Peak/Area 10A Peak Peak Height 12A/Peak Height 10A	35/9 = 4 10/9 = 1

## Montmorillonite

Boiling also enhanced the montmorillonite peak:

<u>Treatment</u>	<u>Mount</u>	<u>Measurements on Glycolated Samples</u>		<u>Ratio</u>
		12A Peak/17A Peak Height	12A Peak Height/17A Peak Height	
Boiled in NaCl	Silver Membrane			33/4 = 8
	Glass Slide			6/1 = 6
Not Boiled	Silver Membrane	12A Peak Height/17A Peak Height		6/1 = 6
	Glass Slide	17A Peak not Discernible		$\infty$

### Conclusion

Some montmorillonite is present in the "as-received" mud, but not much.

### Kaolinite

Kaolinite/berthierine (7A peak) does not appear to be altering to any other phase. In the following table, ratios of muscovite peak heights (10A) to 7A peak heights show no significant variations:

<u>Terra Tek Sample No.</u>	<u>GLYCOLATED</u>			<u>AIR DRIED</u>		
	<u>7A Peak Height</u>	<u>10A Peak Height</u>	<u>10A/7A</u>	<u>7A Peak Height</u>	<u>10A Peak Height</u>	<u>10A/7A</u>
RGI-11 Boiled Glass Slide	1.25	6	4.8	1.5	7	4.7
RGI-11 Boiled Silver Membrane	2	8	4	2.25	8	3.6
RGI-11 Untreated Glass Slide	1.5	9	6	1.5	8.5	5.7
RGI-11 Untreated on Silver Membrane	0.5	3	6	0.5	3	6
	Average		5.2			5.0

Terra Tek Sample No.	GLYCOLATED			AIR DRIED		
	7A Peak Height	10A Peak Height	10A/7A	7A Peak Height	10A Peak Height	10A/7A
RGI-15A Glass Slide	4.75	18.5	3.9	5	18.5	3.7
RGI-15 Silver Membrane	1.75	7	4	1.5	4	2.7
RGI-18 Glass Slide	3.5	23	6.6	3.5	22	6.3
RGI-18 Silver Membrane	1.5	5.5	3.7	1.5	5.5	2.7
72 hrs. at 250°C	4	26	6.5	4	24	6
			<u>4.9</u>			<u>4.3</u>
	Average					

### Conclusions

As-received sepiolite drilling mud contains a trace amount of montmorillonite. Montmorillonite estimated abundance was not significantly enhanced by preparing a silver membrane sample mount relative to the glass plate mount. Kaolinite does not appear to be undergoing significant hydrothermal alteration. Enhancement of montmorillonite abundance as a function of increasing temperature appears to be a hydrothermal alteration reaction involving sepiolite. However, the absolute quantity of hydrothermally altered sepiolite at temperatures to 250°C does not appear to be significant.

## APPENDIX IV

### Preparation of Acid Solutions

All percentages are expressed as weight percents unless otherwise indicated. The basis for all calculations is 100 grams acid mixture. Reagent grade concentrated hydrochloric acid was used in all cases. Hydrofluoric acid was prepared from reagent grade ammonium hydrogen fluoride  $\text{NH}_4\text{F}\cdot\text{HF}$ .

#### 5% Hydrofluoric Acid - 10% Hydrochloric Acid Mixture

$$5\% \text{ HF} = 5\text{g HF} \times \frac{\text{mol HF}}{20.01 \text{ g HF}} = 0.250 \text{ mol HF}$$

This amount of HF can be generated by the dissolution of ammonium hydrogen fluoride,  $\text{NH}_4\text{F}\cdot\text{HF}$  in the reaction

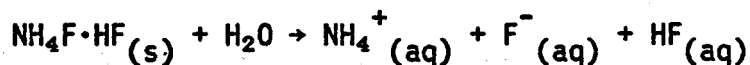

The aqueous dissociation of HF

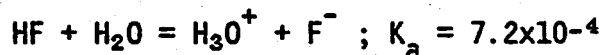

is extremely low. However, the association with the fluoride ion is moderate

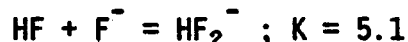

and about 65% of the HF will exist as the complex ion  $\text{HF}_2^-$ , and the remainder will be the neutral HF molecule. In any case, the molar concentration of HF is determined by the sum of these two species. The  $\text{NH}_4^+$  and  $\text{F}^-$  will not constitute a source of HF since  $\text{NH}_4^+$  will not donate a proton in acid solutions.

Therefore, the mole ratio of HF to  $\text{NH}_4\text{F}\cdot\text{HF}$  is 1 to 1, so:

$$0.250 \text{ mol HF} \times \frac{\text{mol NH}_4\text{F}\cdot\text{HF}}{\text{mol HF}} \times \frac{57.04 \text{ g NH}_4\text{F}\cdot\text{HF}}{\text{mol NH}_4\text{F}\cdot\text{HF}} = 14.26 \text{ g NH}_4\text{F}\cdot\text{HF}$$

is required.

The addition of HF in the ammonium salt form will introduce the salt  $\text{NH}_4\text{F}$  into the solution at a concentration of

$$14.26 \text{ g NH}_4\text{F}\cdot\text{HF} \times \frac{37.04 \text{ g/mol NH}_4\text{F}}{57.04 \text{ g/mol NH}_4\text{F}\cdot\text{HF}} = 9.26 \text{ g NH}_4\text{F} = 9.26\%$$

The balance of the solution will be 10% HCl and 75.74%  $\text{H}_2\text{O}$ . The solution is made by dissolving the salt in a solution of 10 g HCl and 75.74 g  $\text{H}_2\text{O}$ . This HCl solution concentration is

$$\frac{10 \text{ g HCl}}{(10 + 75.74) \text{ g solution}} = 0.1166$$

By using the density of 11.66% HCl solution, the volume required is found to be

$$85.74 \text{ g Sol} \times \frac{\text{ml}}{1.0559 \text{ g}} = 81.2 \text{ ml of 11.66\% HCl}$$

The HCl solution is prepared from concentrated HCl (37% HCl, density of 1.1492). A 100 ml volumetric flask is a convenient measure which will give

$$100 \text{ ml} \times \frac{1.0559 \text{ g}}{\text{ml}} = 105.59 \text{ g acid solution}$$

The amount of concentrated HCl to be diluted is calculated to be

$$105.59 \text{ g Sol} \times \frac{0.1166 \text{ g HCl}}{\text{g sol}} \times \frac{\text{g con HCl}}{0.37 \text{ g HCl}} = 33.28 \text{ g conc HCl}$$

This volume is

$$33.28 \text{ g con HCl} \times \frac{\text{ml}}{1.1492 \text{ g}} = 28.96 \text{ ml con HCl}$$

In summary, a 5% HF-10% HCl mixture was prepared as follows:

1. Dilute 29.0 ml conc HCl to 100 ml in a volumetric flask.
2. Weigh 14.26 g  $\text{NH}_4\text{F}\cdot\text{HF}$  into a plastic beaker.
3. Pour 81.2 ml of the HCl solution into the beaker.

#### Preparation of a 3% Hydrofluoric Acid - 12% Hydrochloric Acid Mixture

The process and logic are the same as above, and so to avoid redundancy, only the mathematical equations are presented below:

$$3\% \text{ HF} = 3 \text{ g HF} \times \frac{\text{mol HF}}{20.01 \text{ g HF}} = 0.150 \text{ mol HF}$$

$$0.150 \text{ mol HF} \times \frac{\text{mol NH}_4\text{F}\cdot\text{HF}}{\text{mol HF}} \times \frac{57.04 \text{ g NH}_4\text{F}\cdot\text{HF}}{\text{mol NH}_4\text{F}\cdot\text{HF}} = 8.556 \text{ g NH}_4\text{F}\cdot\text{HF}$$

$$8.556 \text{ g NH}_4\text{F}\cdot\text{HF} \times \frac{37.04 \text{ g/mol NH}_4\text{F}}{57.04 \text{ g/mol NH}_4\text{F}\cdot\text{HF}} = 5.556 \text{ g NH}_4\text{F} = 5.56\%$$

$$\frac{12 \text{ g HCl}}{(12 + 79.44) \text{ g solution}} = 0.1312 \text{ or } 13.12\% \text{ HCl}$$

$$91.44 \text{ g sol} \times \frac{\text{ml}}{1.0632 \text{ g}} = 86.01 \text{ ml of } 13.12\% \text{ HCl}$$

$$100 \text{ ml} \times \frac{1.0632 \text{ g}}{\text{ml}} = 106.32 \text{ g of } 13.12\% \text{ HCl}$$

$$106.32 \text{ g sol} \times \frac{0.1312 \text{ g HCl}}{\text{g sol}} \times \frac{\text{g conc HCl}}{0.37 \text{ g HCl}} = 37.70 \text{ g conc HCl}$$

$$37.70 \text{ g conc HCl} \times \frac{\text{ml}}{1.1492} = 32.81 \text{ ml conc HCl}$$

In summary, a 3% HF-12% HCl mixture was prepared as follows:

1. Dilute 32.8 ml conc HCl to 100 ml in a volumetric flask.
2. Weight 8.556 g NH<sub>4</sub>F·HF into a plastic beaker.
3. Pour 86.0 ml of the HCl solution into the beaker.

## APPENDIX V

### Composition of Attapulgate and Sepiolite Mud Systems

#### Attapulgate Mud System

58	1b/bbl	attapulgate (SALT GEL)
2	1b/bbl	lignite (TANNATHIN)
2	1b/bbl	guebracho
.75	1b/bbl	caustic soda
10	1b/gal	barite
3000	ppm	sodium chloride

#### Mud Properties:

Weight	- 10.0 ppg
F. Vis.	- 45.5 sec/qt
P. Vis.	- 13 cp at 115 F
Yield Point	- 21 lb/100 sq ft at 115 F
Gel Strength	- 22 at 10 sec, 88 at 10 min
pH	- 11.5
Filtrate	- 57.5 cc API, 100 psi, 30 min
Salt	- 3000 ppm

#### Sepiolite Mud System

18	1b/bbl	sepiolite
2	1b/bbl	polymer (THERMPLEX)
.75	1b/bbl	caustic soda (10.5 pH)
1	1b/bbl	sodium polyacrylate (WL-100)
1	1b/bbl	oil substitute (THERMLUBE)

APPENDIX VI

Composition of Acid-Effluent-Precipitate:  
Results of Elemental Analysis

<u>Element</u>		<u>Concentration</u>
Na	% Oxide	0.183
K	% Oxide	0.105
Ca	% Oxide	<0.072
Mg	% Oxide	0.213
Fe	% Oxide	0.792
Al	% Oxide	1.07
Si	% Oxide	<33.1
Ti	% Oxide	0.046
P	% Oxide	0.144
Sr	PPM	47
Ba	% Oxide	1.15
Cr	PPM	5000
Ni	PPM	537
Cu	PPM	118
Mo	PPM	5636
Zn	PPM	160